

Quality Gage & Valve “Steam-Line” Products

(You won’t get “steamed” with us)

TB-32 “Steam Line” Direct Reading Steam/Water Gages For 750 PSI (Working Steam Pressure) WSP

Durable Construction for Optimal Performance
A.S.M.E. Sec.1 Compliant
Recessed Gasket in Chamber and Cover

Custom Built to Meet Your Requirements
Spring Washers for Constant Torque
Special Coating for Steam Service
Multiple Connections Available
High Quality Mica Shield for Glass Protection



The “Steam Line” TB32 units are designed for steam service to 750WSP. These Gages can be used as Direct Reading Sight Glass for boilers in compliance with A.S.M.E. PG-60. Visible ranges are achieved by using multiple sections with a minimum 1” overlap to ensure continuous visibility. The gage chamber is reinforced with internal tie bars to add durability to the product, and remove the possibility of lateral deflection, which can cause early gasket failure. All units are supplied with recessed gasket seats and forged covers which allow for easy and inexpensive maintenance.

Materials of Construction:

1) Cover:	Forged Carbon Steel
2) Chamber:	Carbon Steel
3) Glass:	Tempered Borosilicate
4) Gaskets:	Grafito c/w ss binder
5) Mica	HQ Mica
6) U-Bolts:	A193-B7
7) Nuts:	A194-2H
8) Washers	17-7 PH S.S.

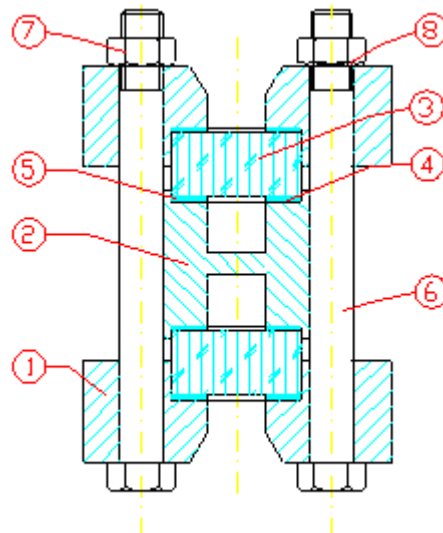

“Steam-Line” TB32 – 750 WSP Steam/Water Gages

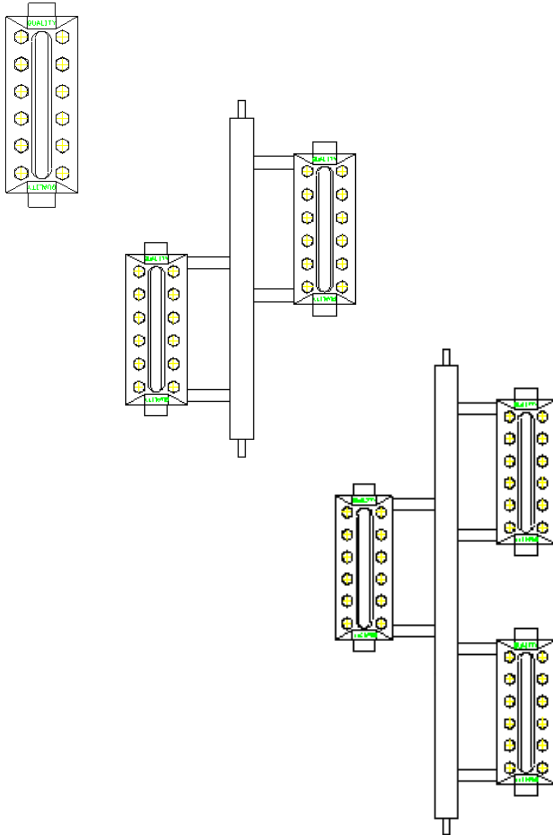

Model	Visible Inches	Glass mm
Q16TB32	9-1/8	232
Q17TB32	10-1/4	260
Q18TB32	11-7/8	302
Q19TB32	12-5/8	320
Q26TB32	17-1/4	438
Q27TB32	19-1/2	495
Q28TB32	22-3/4	578
Q29TB32	24-1/4	616
Q37TB32	28-3/4	730
Q38TB32	33-5/8	854
Q39TB32	35-7/8	911
Q47TB32	38	965
Q48TB32	44-1/2	1130
Q49TB32	47-1/2	1207
Q58TB32	55-3/8	1407
Q59TB32	59-1/8	1502

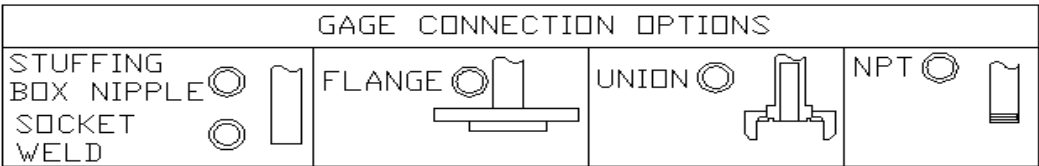

Connection Type:

- NPT = Threaded
- SW = Socket Weld
- UN = Union
- FL = Flanged

Connection Location:

- Top/Bottom Connected =STD
- Side/Side Connected =CH
- Top Side/Bottom Connected=TCH
- Bottom Side/Top Connected=BCH

Connection Sizes Available:

- 1/2"
- 3/4"
- 1"

Quotation Information Required: Maximum Operating Steam Pressure
 Steam Water Connection Size & Type
 Valve Requirements